

Typical Garage Pad Construction

Not drawn to scale

City of Lakewood, Ohio
Division of Building and Housing
12650 Detroit Avenue
Lakewood, Ohio 44107
(216) 529-6270
Fax (216) 529-5930

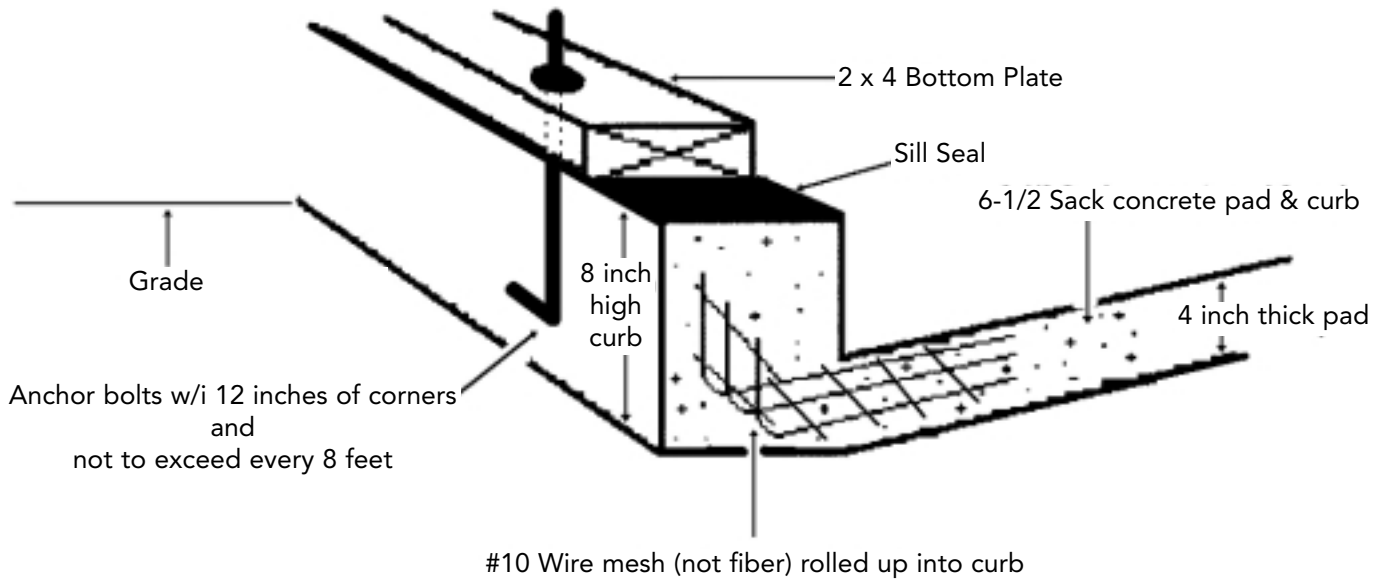

Pad to be placed on undisturbed earth or compacted fill.

Call for (required) inspection of forms, stone & mesh prior to placing the pour.

Garage pad to be _____ feet wide by _____ feet deep.

Garage to be constructed in Zoning District _____.

Property Address is _____

Garage to be constructed _____ inches from rear yard line and _____ inches from side yard line.

Provide plot plan showing property dimensions and location of garage.

Owner Name _____ Owner Phone _____

Contractor Name _____ Contractor Phone _____

This drawing is for permit application only. It is not to be used as construction document.